

TOP VIEW

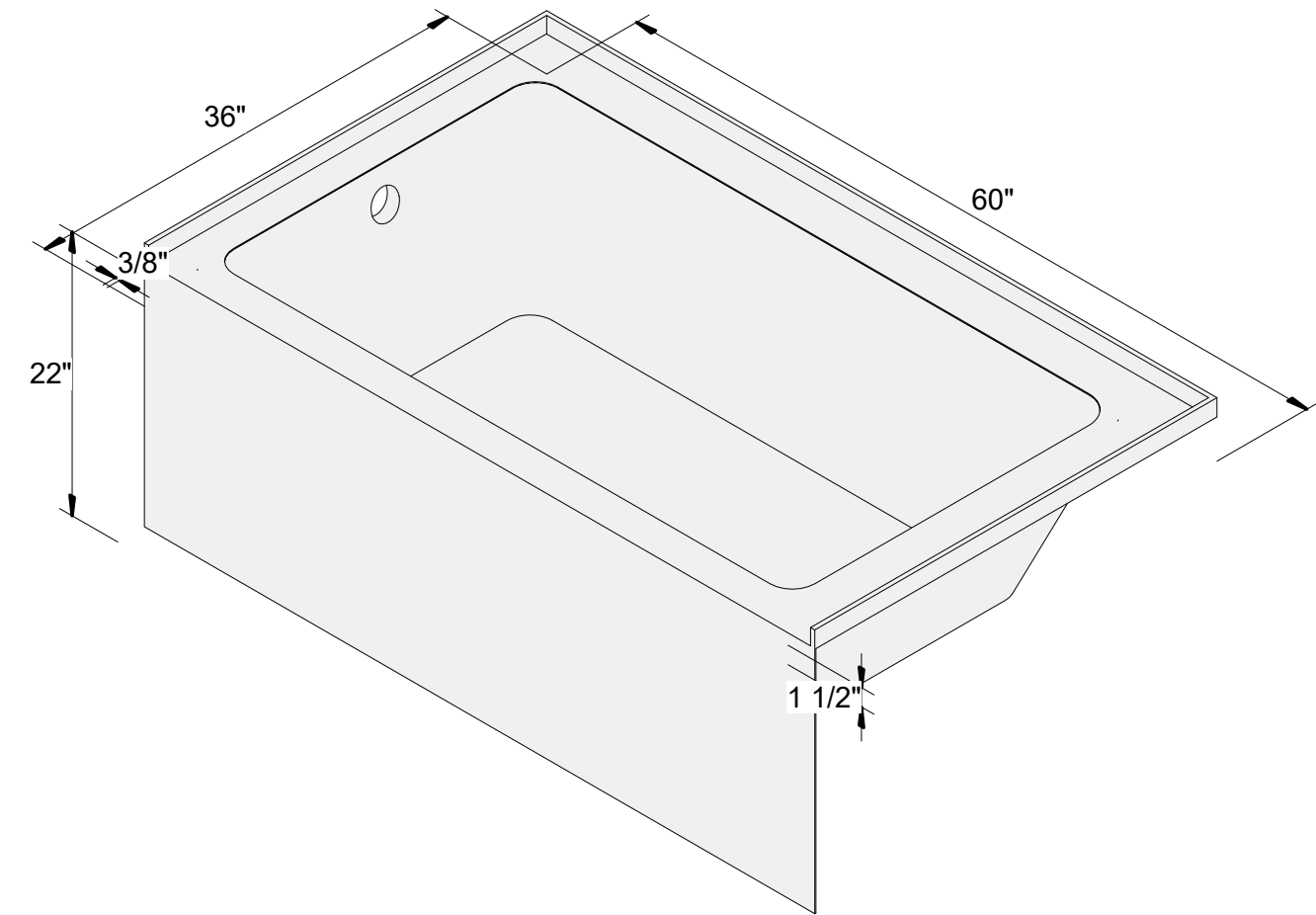

ISO VIEW



SIDE VIEW

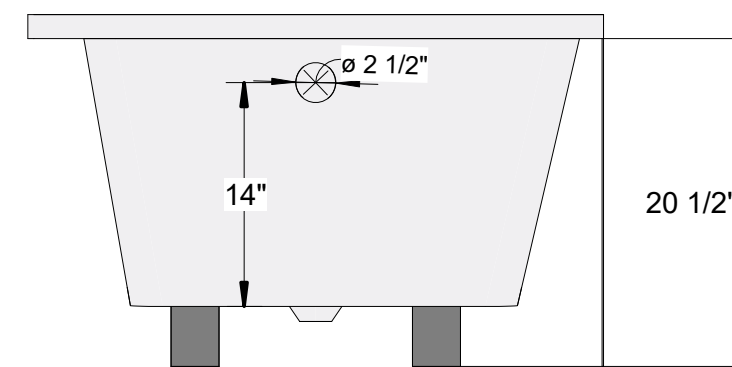

FRONT VIEW

TECHNICAL SPECIFICATIONS:

- LEFT OR RIGHT HAND DRAIN AVAILABLE
- CAPACITY: 69 GALLONS
- WEIGHT: - LBS

CODES/ STANDARDS

CSA B45.5-22
IAMPO Z124-2022



HARLAN AFD 60 x 36

SIZE	DRAWN	DWG NO	REV
C	GYAMFUAH 10/2024	6D-2024-11	
SCALE	1" = 1'-0"	TOLERANCE +/- .38	Sheet 18