

TOP VIEW

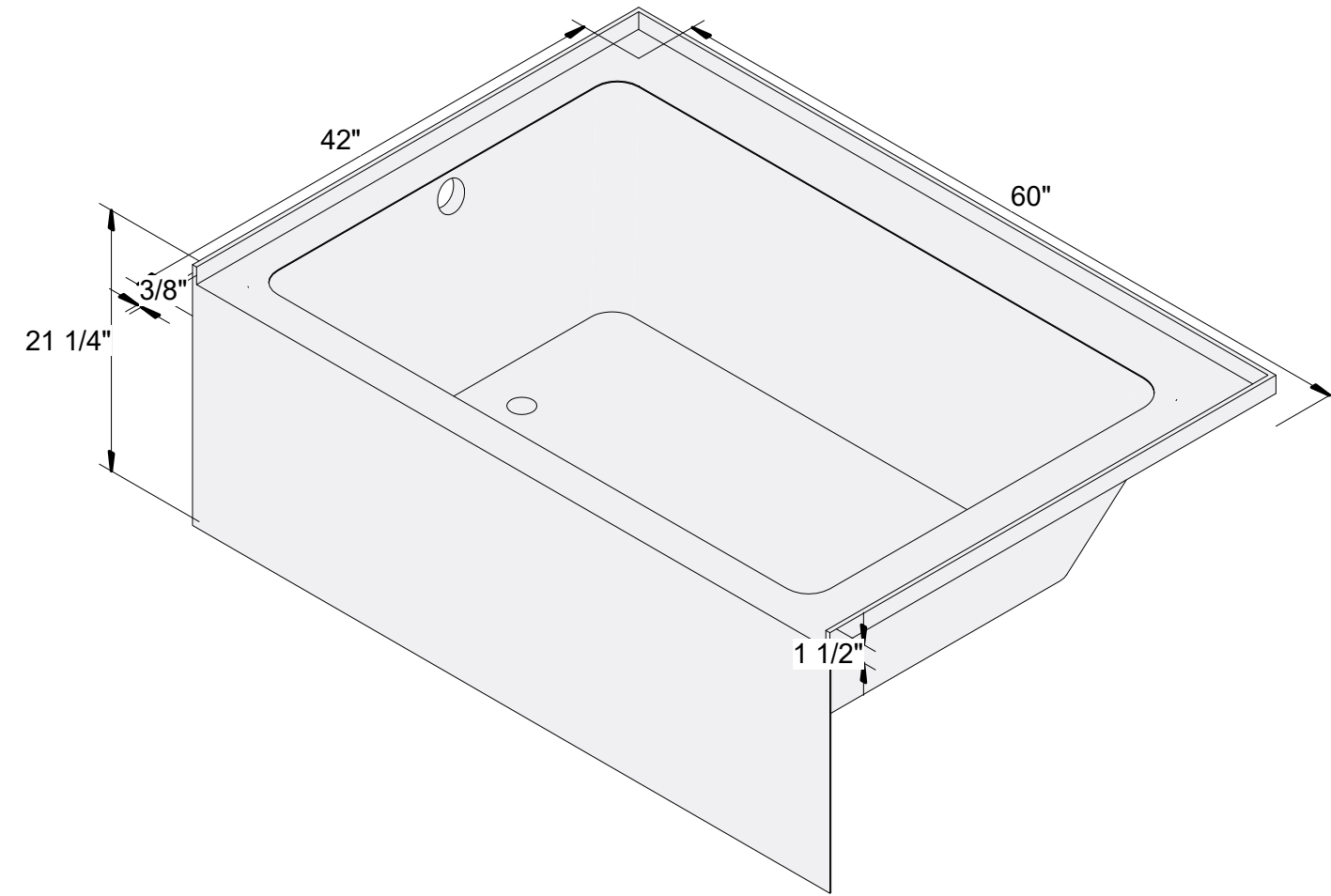

ISO VIEW

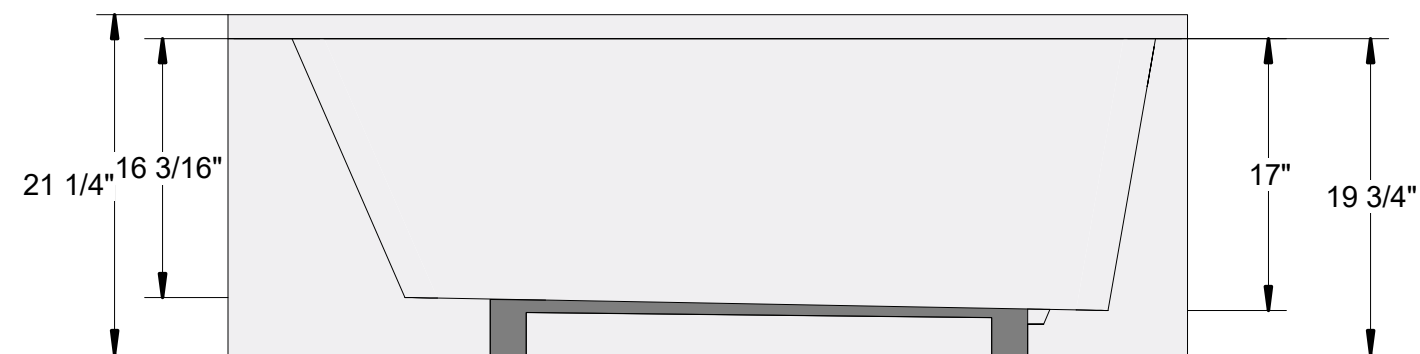

SIDE VIEW

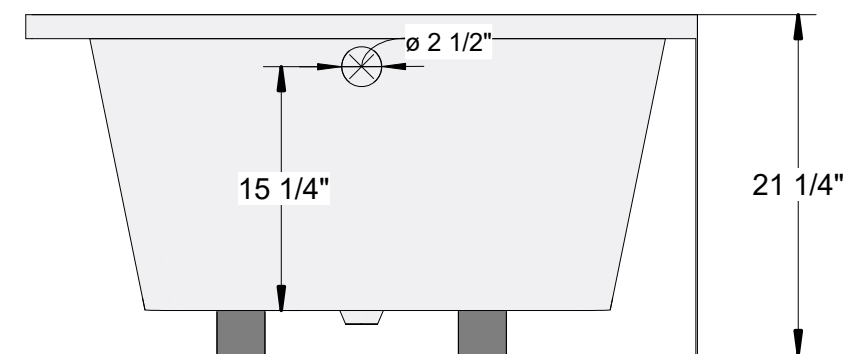

FRONT VIEW

**TECHNICAL SPECIFICATIONS:**

- LEFT OR RIGHT HAND DRAIN AVAILABLE
- CAPACITY: 81 GALLONS
- WEIGHT: - LBS

**CODES/ STANDARDS**

CSA B45.5-22  
IAMPO Z124-2022



# HARLAN AFD 60 X 42

SIZE	DRAWN	DWG NO	REV
C	GYAMFUAH 10/2024	6E-2024-11	
SCALE	1" = 1'-0"	TOLERANCE +/- .38	Sheet 19